



ASSEMBLY INSTRUCTIONS

ITEM 61938, Veracruz All Weather Wicker 5 Piece Bar Set



Table of Contents:

General Information.....	Page 2
Safety Information.....	Page 2
Preparation.....	Page 2
Parts List.....	Page 3
Assembly.....	Page 4-5
Warranty Information.....	Page 6

****IMPORTANT NOTICE****

Do **NOT** return to place of purchase. For customer Service and warranty issues, please contact our **TOLL FREE HOTLINE: 866-985-7877** or Email: cservice@welltraveled.net.
Hotline hours: Mon – Fri, 9AM to 6PM, EST

SAVE THESE INSTRUCTIONS FOR FUTURE REFERENCE.



ITEM 61938, Veracruz All Weather Wicker 5 Piece Bar Set

GENERAL INFORMATION:

Your new Wicker Bar Set is made from the finest materials available. It should provide many years of enjoyment with minimal care.

Keep your Wicker Bar Set clean. For best results, clean the Wicker Bar Set with a soft, damp cloth. If you use furniture covers, always make sure the Wicker Bar Set is clean and completely dry before covering as mold may form in dark, wet places. Remove cushions prior to covering and store them in a dry, temperature controlled place. Check the screws on your Wicker Bar Set regularly to make sure they are tight.

SAFETY INFORMATION:

WARNING

DO NOT stand or allow children to stand on the assembled product.

DO NOT tighten screws completely until instructed to do so. After final alignment, make sure all screws are securely fastened.

NEVER use a power tool to assemble or tighten your furniture. Perform periodic checks to make sure the hardware is secure and tighten if needed.

CAUTION

READ all instruction before beginning assembly. Failure to do so may result in faulty assembly and potential injury. Assemble the item on a soft, non-abrasive surface such as a carpet or cardboard to avoid damaging the item.

PREPARATION

Before beginning assembly, make sure all parts are present. Compare parts received with the "Parts List." If any part is missing or damaged, do NOT attempt to assemble the product. Contact our Customer Service Hotline toll-free at 1-866-985-7877, Mon – Fri, 9AM to 6PM, EST.



ITEM 61938, Veracruz All Weather Wicker 5 Piece Bar Set

PARTS LIST – CHAIR AND STOOLS x 2 (2 chairs/stools are provided with your set—the 2 stools come pre-assembled)

Seat Frame	1
Seat	1

HARDWARE LIST – CHAIR x 2

AA	M6x12 Bolts	3
BB	M6 Lock Washers	3
CC	M6 Washers	3

PARTS LIST - TABLE

Table Top	1
Leg Panels	4

HARDWARE LIST - TABLE

AA	M6x16 Bolts	8
BB	M6x35 Bolts	4
CC	M6 Lock Washers	12
DD	M6 Washers	12

PLEASE NOTE: A wrench for tightening the hardware is also included with this item.



ITEM 61938, Veracruz All Weather Wicker 5 Piece Bar Set
ASSEMBLY

CHAIR (x2)

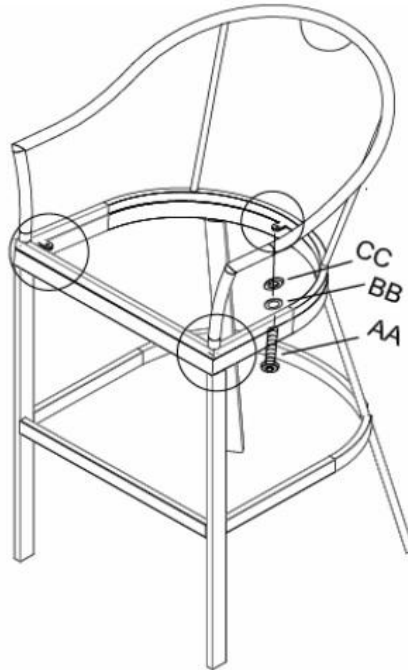

- 1.** Align the Seat to the Seat Frame. Insert 1 – M6x12 Bolt (AA) through 1 – M6 Lock Washer (BB) and 1 – M6 Washer (CC) and then into the holes in the Seat/Seat Frame. Loosely tighten with wrench. Repeat with 2 more sets of hardware.
- 2.** Tighten all hardware with wrench. Your chair is now ready for use!



ITEM 61938, Veracruz All Weather Wicker 5 Piece Bar Set

ASSEMBLY

TABLE

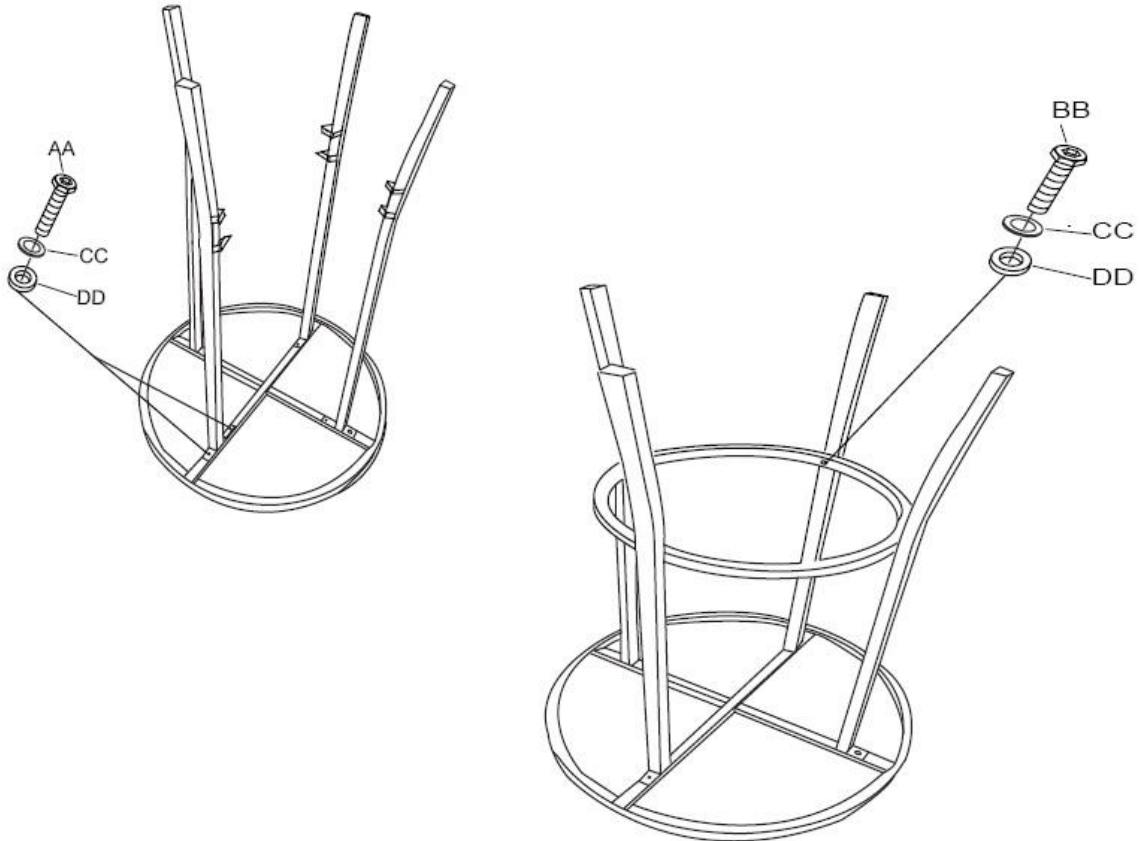

1. Lay the Table Top flat on a soft, level surface. Align the hole in the top of the Leg with the hole found on the underside of the Table Top and insert 2 – M6x16 Bolt (AA) through 2 – M6 Lock Washer (CC) and 2 – M6 Washer (DD) and through the holes in the Leg and Table. Loosely tighten with wrench. Repeat with the other 3 – Legs. (NOTE: DO not fully tighten yet as you may need to adjust the Legs to allow the Table Ring to affix properly in Step 2.)

2. Align the holes in the Lower Table Ring with the holes in the Legs. Insert 1 – M6x35 Bolt (BB) through 1 – M6 Lock Washer (CC) and 1 – M6 Washer (DD) and through the holes in the Lower Table Ring and Leg. Repeat with the other 3 Legs. Tighten securely with wrench and then go back and tighten all hardware.

3. Carefully turn the table up onto the legs. Your table is now ready for use!

Distributed By:
Well Traveled Living
716 S 8th Street
Amelia Island, FL 32034
Toll Free: 866-WTL-SUPP



Web: www.wtliving.com
Email: cservice@welltraveled.net

1 YEAR LIMITED WARRANTY – Customers in the Continental US

All components are warranted for a period of 1 year after date of purchase by the original owner against defects in materials and workmanship under normal use. This warranty does NOT cover normal wear and weathering, assembly and/or maintenance OR use in a commercial application if model is not designated as a commercial model. At Well Traveled Living's sole discretion, products under warranty will be repaired and/or replaced at no charge to the customer. Any returns sent back to Well Traveled Living must be sent via prepaid freight and in the original retail packaging.

For warranty service contact Well Traveled Living at the address, phone numbers or internet site and email listed in this owner's manual. Be sure to have your sales receipt, date of purchase and catalogue/model numbers available when calling. All warranty service will be coordinated by the Well Traveled Living's, Amelia Island, Florida service center.

This warranty is extended only to the original purchaser. Proof of purchase will be required before warranty service is rendered. The sales receipt is the only valid proof of purchase. This warranty only covers failures due to defects in materials or workmanship which occur during normal use. Failures and/or damage which result from accident, negligence, misuse, abuse, neglect, mishandling, alteration or modification, failure to maintain, improper assembly or maintenance, service by unauthorized agency or use of unauthorized components or damage that is attributable to acts of God are NOT covered.

*****THERE ARE NO EXPRESS WARRANTIES EXCEPT AS LISTED ABOVE*****

*****PURCHASER ASSUMES ALL RISKS IN THE ASSEMBLY AND OPERATION OF THIS UNIT*****

*****FAILURE TO FOLLOW WARNINGS AND OPERATIONAL INSTRUCTIONS CONTAINED IN THIS MANUAL CAN RESULT IN SEVERE PROPERTY DAMAGE AND/OR PERSONAL INJURY*****

IN NO EVENT WILL WELL TRAVELED LIVING, OR ITS DIRECTORS, OFFICERS OR AGENTS BE LIABLE TO THE PURCHASER OR ANY THIRD PARTY, WHETHER IN CONTRACT, IN TORT, OR ON ANY OTHER BASIS, FOR ANY INDIRECT, SPECIAL, PUNITIVE, EXEMPLARY, CONSEQUENTIAL, OR INCIDENTAL LOSS, COST, OR DAMAGE ARISING OUT OF OR IN CONNECTION WITH THE SALE, MAINTENANCE, USE, OR INABILITY TO USE THE PRODUCT, EVEN IF WELL TRAVELED LIVING OR ITS DIRECTORS, OFFICERS OR AGENTS HAVE BEEN ADVISED OF THE POSSIBILITY OF SUCH LOSSES, COSTS OR DAMAGES, OR IF SUCH LOSSES, COSTS, OR DAMAGES ARE FORESEEABLE. IN NO EVENT WILL WELL TRAVELED LIVING, OR ITS OFFICERS, DIRECTORS, OR AGENTS BE LIABLE FOR ANY DIRECT LOSSES, COSTS OR DAMAGES THAT EXCEED THE PURCHASE PRICE OF THE PRODUCT.

SOME JURISDICTIONS DO NOT ALLOW THE EXCLUSION OR LIMITATION OF INCIDENTAL OR CONSEQUENTIAL DAMAGES, SO THE ABOVE LIMITATION OR EXCLUSION MAY NOT APPLY TO THE PURCHASER.

This limited warranty gives you specific legal rights and you may also have other rights which vary from jurisdiction to jurisdiction. The provisions of the United Nations Convention on Contracts for the Sales of Goods shall not apply to this limited warranty or the sale of products covered by this limited warranty.

*****IMPORTANT NOTICE*****

-Do **NOT** return to place of purchase-

For customer service and warranty issues

contact our Customer Service Center at:

(866)-985-7877 OR

Email: cservice@welltraveled.net

Customer Service Hours: Mon. – Fri. 9:00 a.m. – 6:00 p.m. (EST)

Fire Sense®, Patio Sense®, Mojave Sun®, and Well Traveled Living® are registered trademarks of Well Traveled Imports, Inc®. All assembly instruction presentations are the property of Well Traveled Imports, Inc.® and are protected by U.S. copyrights and trademarks. All rights reserved.